

Chios Wall Faced



Ceramic wall faced toilet suite

- Wall faced – sits flat against wall
- Cistern and pan white vitreous china
- Soft closing seat, quick release with stainless steel pins
- Suitable for S or P trap
- Suits back entry inlet or bottom entry inlet

CISTERN	Suits back entry inlet or bottom entry plumbing. Left and right bottom entry inlet points.
PAN	Wall faced close coupled with box flushing rim.
TRAPS	Universal trap, suitable for S or P trap installations.
SEAT	Quick release seat with stainless steel hinges, soft closing.
WELS	4 star rating 4.5/3 litre water saving flush.
SETOUT	Variable 90-180mm using supplied connector; 140mm recommended.
FIXING	This is a close coupled toilet suite — the cistern is fixed directly to the pan and does not require wall fixing. Pan may be bedded with cement base or using silicone sealant.

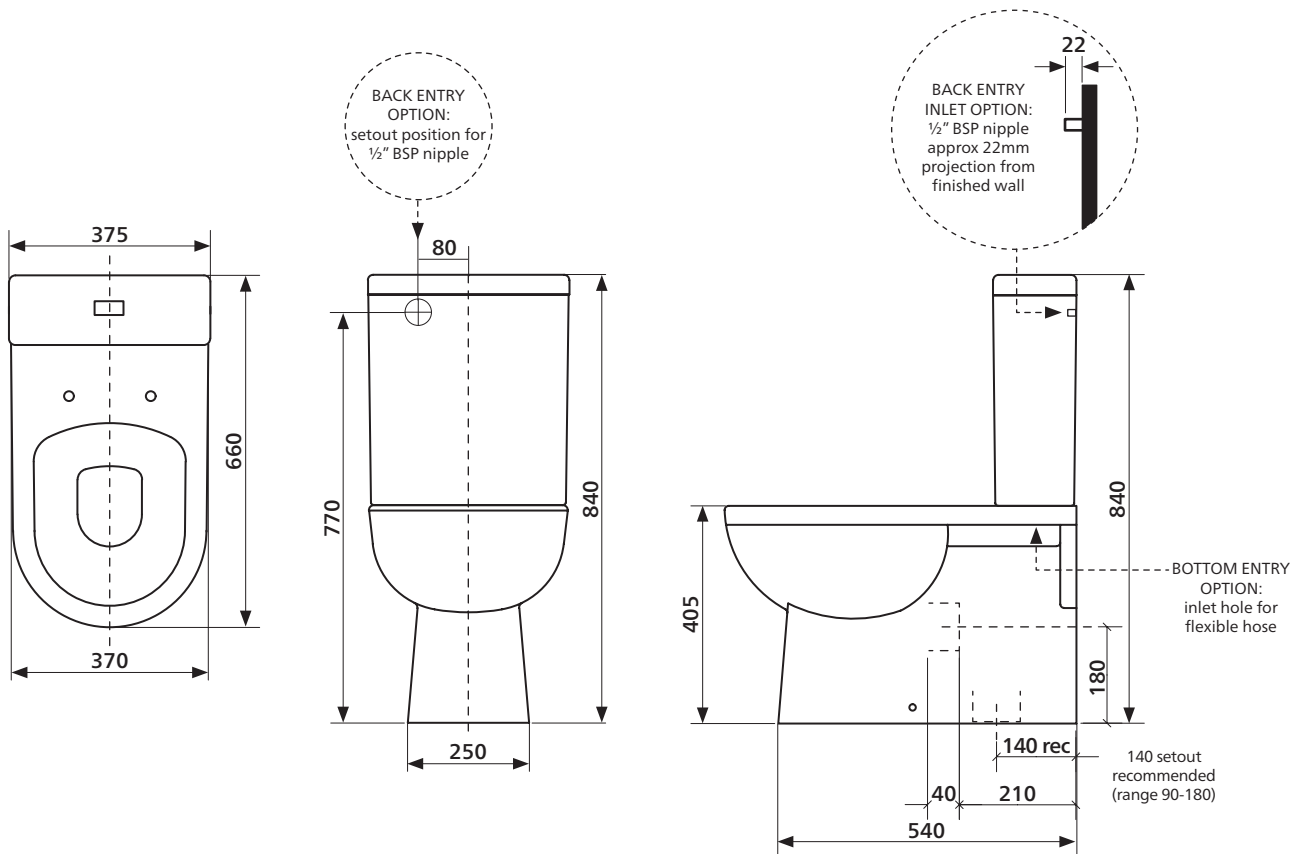

SEIMA

kitchen + laundry + bathroom ware

seima.com.au

Please note

- Installation shall be in accordance with AS/NZS3500.
- All measurements are in millimetres. Height dimensions are to base of pan. Make allowance for bedding.
- Bedding: Pan may be bedded with cement base or using silicone sealant. Fix pan to floor using a sand cement mixture of 3:1 to a depth of 60mm. Do not use lime or fast-drying cement.

- Bracket fixing: The pan should be bedded with silicone sealant and fixed with the brackets supplied.
- Do NOT use epoxy type adhesives.
- Dimensions are nominal and subject to normal ceramic manufacturing variations.
- Specifications may vary without notice as part of our continuous improvement practices.
- Clean with a damp cloth. Do not use abrasive cleaners, liquids or pastes.

Installation Guide

Chios Wall Faced

IMPORTANT

- 1 Inspect the components **before installation** to ensure there are no visible defects. If a defect is found, do not install the toilet suite and contact the supplier immediately. Claims for defects will not be accepted after the product has been installed.
- 2 This wall faced toilet suite is suitable for:
CISTERN — either **Bottom Entry Inlet** (left or right stop valve) or **Back Entry Inlet**.
PAN — **Universal Trap** — accommodates S-trap installation or P-trap installation (using appropriate connector, not supplied).
- 3 The toilet suite must be installed by a **licensed plumber**. Failure to do so may void the warranty.
- 4 Installation must be in accordance with AS/NZS3500.

CISTERN PACKAGE CONTENTS

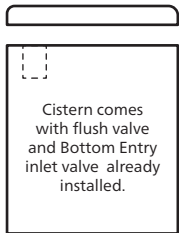

- 1 x ceramic cistern lid
 - 1 x ceramic cistern base containing:
 - 1 x flush valve
 - 1 x bottom entry inlet valve
- Cistern is supplied with flush valve and Bottom Entry inlet valve already installed. See Diagram A.

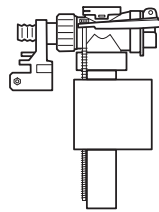

- Optional with BE versions:
 - 1 x back entry inlet valve
- Note: This component is only supplied with Back Entry version.



- 2 x bolts w seals
- For attaching cistern to pan.



- 1 x plug
- Only required if installing back entry (BE) version.



- 1 x rubber seal
- For sealing outlet at base of cistern.

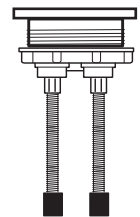

- 1 x flush button

PAN PACKAGE CONTENTS

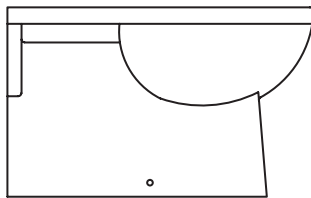

- 1 x ceramic pan

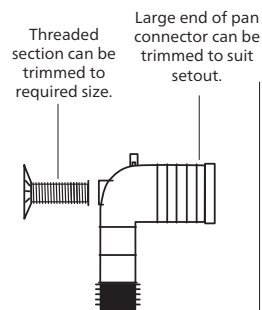

- 1 x pan connector
- For connecting pan to floor outlet pipe/S-trap.
- 1 x threaded section (with flange plate)
- Flange attaches to wall; threaded section links to pan connector.

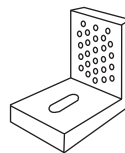

- 2 x concealed fixing brackets

Optional — can be used to connect pan to floor.

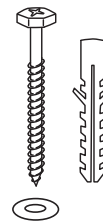

- 2 x floor bolts (+ white plugs)
- 2 x washers

Optional fixing #2 — used with fixing brackets to secure pan to floor. Bolt is inserted through bracket base hole.



- 2 x caps (chrome plated)
- 2 x screws
- 2 x pan plugs (white)

Optional fixing #2 — used to secure pan to concealed fixing bracket. Plastic plug is placed into hole in side of pan exterior, screw is rebated into plug and then screws into a hole in upright section of bracket. Chrome cap is used to cover plastic plug.

SEAT PACKAGE CONTENTS

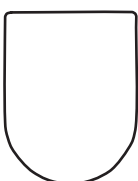

- 1 x seat and lid
- Has receptor holes that slide onto stainless steel pins.

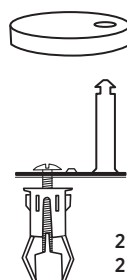

- 2 x stainless steel caps (used to cover stainless steel plate with pin)
- 2 x stainless steel plates with pin (seat locates onto stainless steel pins)
- 2 x toggle bolts (used for securing stainless steel plate and pin to pan)

1 S-TRAP PROCEDURE — SECURING THE PAN CONNECTOR IN PLACE

Determine the centre of the pan and mark the centre line on the floor and wall.

Work out the setout required. The recommended setout is 140mm (setout range is 90-180mm).

You may need to trim the large end of the plastic **pan connector** to fit the required setout. To trim, first remove the plastic ring and rubber seal, then cut pipe to size. Refit rubber seal and plastic ring securely, ensuring a good fit.

Position the pan connector into the floor outlet pipe (S-trap). The height measurement from the floor to the centre of the pan connector is 180mm.

Slot the **threaded section (with flange plate)** onto the pan connector, ensuring that the flange plate is touching the wall. You may need to trim the threaded section so that it fits properly.

Mark and drill the flange plate holes and secure the plate to the wall with fixing screws. The pan connector is now installed.

2 POSITIONING THE PAN

Use the centre line marked on the wall and floor to position the **pan**. Push the pan into the installed plastic pan connector. It is recommended that wedges are used to support the foot of the pan during positioning.

3 BOTTOM ENTRY INLET CONNECTION — SET-UP

SEE DIAGRAM A.

The **bottom entry inlet valve** is already installed on the right side of the cistern. The position can be swapped to the left side if required.

Connect the flexible inlet hose to the stop valve and water control inlet valve on the wall. Leave flexible inlet hose unsecured for now — for the bottom entry inlet connection, the flexible inlet hose will be connected to the cistern's inlet valve in item #6 below.

4 OPTIONAL BACK ENTRY INLET CONNECTION — CISTERN SET-UP

(Note: The cistern comes supplied with the bottom entry inlet valve already installed and this needs to be removed.)

To set up the back entry connection, first remove the bottom entry inlet valve on the right side the cistern. DIAGRAM B STEP 1.

Use the **plug** supplied to securely fill the hole in the base of the cistern. DIAGRAM B STEP 2.

For ease of access while connecting the **back entry inlet valve**, temporarily remove the flush valve from the cistern.

Place the cuff of the back entry inlet valve onto the overflow pipe of the flush valve, and fully tighten the wing nut. DIAGRAM B STEP 3.

Re-fit the flush valve and back entry inlet valve to cistern.

Connect the **flexible BE hose** to the 1/2" BSP nipple. Run the flexible BE hose behind the flush valve, ensuring that the hose does not obstruct the operation of the flush valve. DIAGRAM C.

5 SECURING THE PAN ON THE FLOOR

Cement fixing (optional fixing #1)

If using cement bedding, level the pan while the cement mixture is workable. Fix pan to floor using a sand cement mixture of 3:1 to a depth of 60mm. Do not use lime or fast-drying cement.

Important: Allow at least 24 hours for the cement mixture to set before using the toilet.

Bracket fixing (optional fixing #2)

Bed the pan with acetic cured silicone sealant, ensuring that the pan is level. Then position the **concealed fixing brackets** in line with the bracket fixing holes. Screw the **floor bolts** in place through the base of the brackets. Then secure the pan to the brackets using the plastic **pan plugs** and rebated **screws**. The chrome **caps** can be used to cover the plugs on each side of the pan.

Important: Do not over-tighten the bolts or screws as this may cause the ceramic to crack and break.

DIAGRAM A

BOTTOM ENTRY SET-UP, AS SUPPLIED

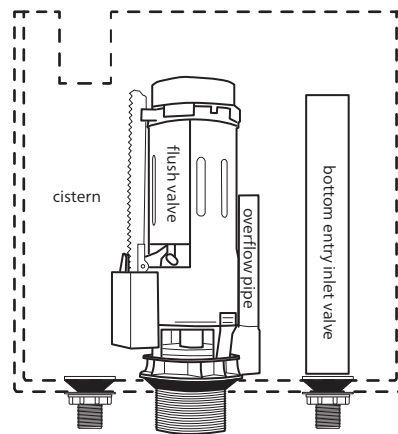

DIAGRAM B

INSTRUCTIONS TO CHANGE SET-UP FROM BOTTOM ENTRY TO BACK ENTRY

For back entry inlet, remove bottom entry inlet valve, plug hole, install back entry inlet valve.

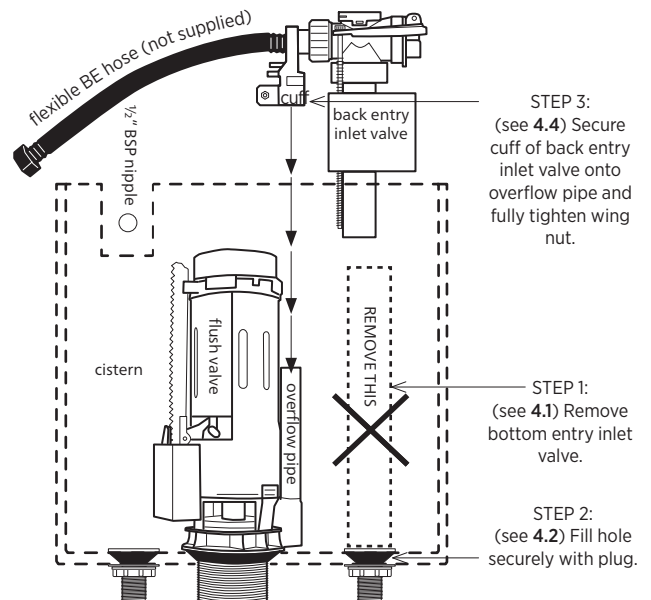
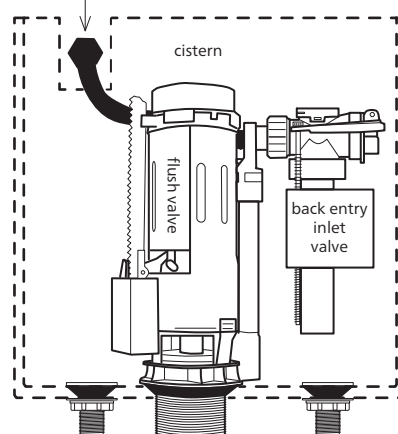

DIAGRAM C

COMPLETED BACK ENTRY SET-UP

(see 4.6) Attach flexible hose (not supplied) to 1/2" BSP nipple water inlet.



6 FIXING THE CISTERN TO THE PAN

First check the alignment of the cistern and pan attachment holes — place the cistern onto the pan and ensure that the holes align. The back of the cistern and pan should line up so that the assembled toilet suite will align with the wall. Now remove the cistern.

Place the **rubber seal** onto the plastic pipe outlet at the base of the cistern and ensure it is securely attached. Locate the cistern outlet (with rubber seal) onto the pan, ensuring a good fit.

If using **bottom entry inlet**, connect the flexible inlet hose (see item #3 above) to the cistern's water control valve on the base of the cistern. (Ignore this if using back entry connection.)

Now secure the cistern to the pan using the two **bolts with seals** in the cistern/pan attachment holes. SEE DIAGRAM D.

Flush the lines and connect the water supply and check the operation of the cistern.

7 FITTING THE CISTERN LID

Fit the **flush button** into the cistern lid, with the half flush on the left and full flush on the right. Ensure that the rubber feet of the flush button connect and line up correctly with the flush valve inside the cistern. Fit the **cistern lid** and push the buttons to check operation.

8 OPERATION AND MAINTENANCE

Press the left side half flush to save water and the full flush as required. Clean the toilet with liquid detergent and a damp cloth.

Do not place water additives inside the cistern as this may have chemicals that damage the valves and impair the functionality of the cistern.

9 SEAT INSTALLATION INSTRUCTIONS

Secure the toggle bolts into the seat connection holes, ensuring that the stainless steel pins line up with the receptor holes in the seat. Once correctly placed, ensure that the bolts are properly tightened.

Slide the stainless steel caps onto the plates with pins.

To fit the seat, slide it onto the stainless steel pins. You may need to make adjustments to position the seat correctly.

To remove the seat, put seat in upright position to expose the two chrome seat release buttons at the base of the seat. To release, press both buttons simultaneously and lift the seat upwards to remove it.

